

Hall

FOOD EQUIPMENT

Hydraulic Sausage Fillers

20 kg & 27 kg



Since 1945



Standard inclusions:

- 1 x 1/2 inch Nozzle
- 1 x 14 mm Nozzle
- 1 x 3/4 inch Nozzle
- Hydraulic Oil

Smart by Design, Built to Last

Hall Food Equipment is an Australian owned and operated company and has been manufacturing Butchery Machines in Sydney since 1945. During this time we have successfully expanded our range of Australian made food processing equipment to include Mincers, Sausage Fillers, Mincer Mixers, Burger Press, Chopping Blocks, Preparation Tables & Pickle Pumps.

We pride ourselves on applying smart design, with quality built, durable high finished machines that will last for many years. We give personal attention to all our customers. Our Customer Service aim is to meet and exceed customer expectations through our quality products and true old fashioned customer service.



Knee Operated Lever for hands free operation



Stainless Steel Lid, Nozzle Nut & Nozzles

Intelligent design and decades of experience are combined with a quality finish to produce the Hall Food Equipment Hydraulic Sausage Filler. The Hydraulic (oil) operated Filler is available in two capacities - 20kg and 27kg.

The all stainless steel barrel, exterior body, locking arms, lid, nozzle nut, nozzles and plunger are standard with Hall Food Equipment Sausage Fillers.

The highly polished interior of the stainless steel barrel stops mince sticking to the machine resulting in less wasted product, an easier quicker clean and better hygiene. The bottom line is more profit to the operator from higher yield, reduced time to clean and a visually appealing & longer shelf life product. These features are



sure to please every quality & efficiency conscious operator and most importantly their customers.

The Knee operated Filling Lever allows operators hands to be free for production & controlling casing. Release of the Knee Lever automatically stops the piston and stops the filling process.

Our smart design of a 2" diameter piston & cylinder unit exerts much less strain on the machine, allowing us to reduce the weight of the steel castings of the Hydraulic reservoir & top cylinder plates. This makes our machine lighter than other machines in the market and yet much more durable, reliable & easy to move around. This ease of movement is an important feature for any Health & Safety conscious operator.

Hall Food Equipment Sausage Fillers are extremely versatile and are in use in many different applications, from all meat types, cheese, fruit, vegetables, honey, butter & cosmetics manufacturing.

Hall Sausage Fillers complies with FSANZ & HACCP Standards & is AS/NZS Certified.

Hall Sausage Fillers have snug, close fit panels. Meat and other products won't penetrate the close fitting panel skirts or covers, reducing the chance of foul odours and smells from unseen / hard to reach mince.

Easy clean = Better Hygiene

Hall Food machinery is very Reliable & Durable and given a bit of care will run trouble free for many years. All consumable parts & spares for our machines are reasonably priced & is readily available to minimise the cost of machine maintenance & down time.

Compare our quality, customer service, spare parts prices and availability with other makes of machine and you would realise the benefit of choosing TRUSTED HALL FOOD EQUIPMENT.

Contact us for a list of un-biased Hall Equipment users in your region / state.

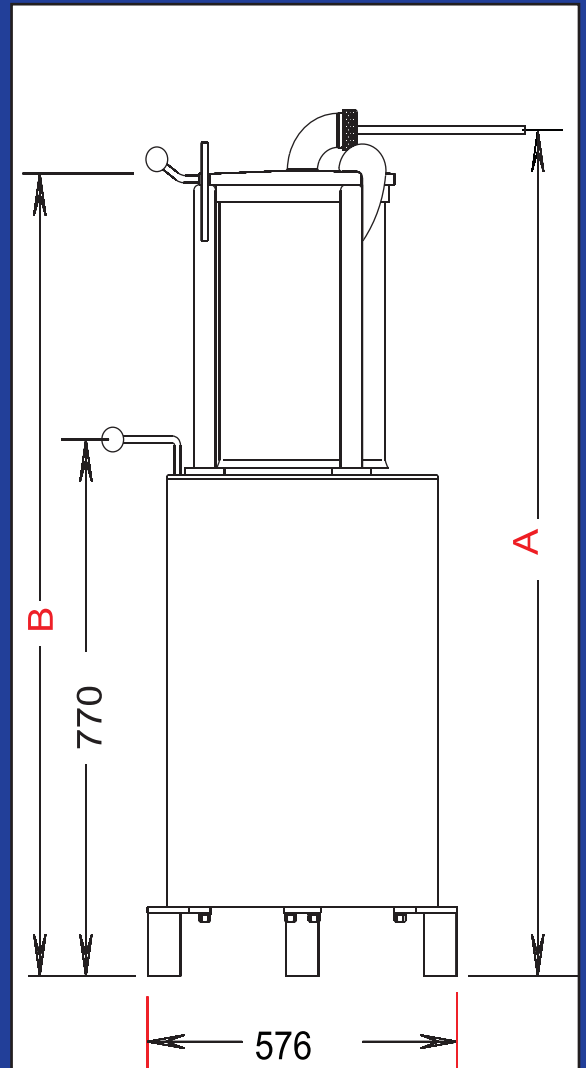

	20kg	27kg
A	1195	1322
B	1140	1267

 CASTOR OPTION AVAILABLE
ADD 20 mm TO HEIGHTS SHOWN

FEATURES

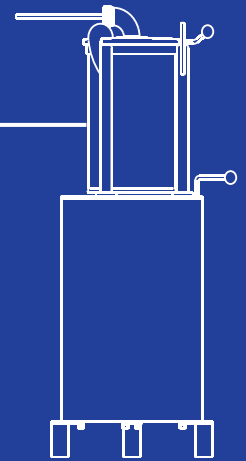

- * Stainless Steel Barrel
- * Stainless Steel Exterior Body
- * Stainless Steel Plunger
- * Stainless Steel Locking Arms
- * Stainless Steel Lid
- * Stainless Steel Nozzles
- * Built in Motor Overload Protection
- * Special purpose designed 2" Diameter piston & Cylinder for superior smooth performance & much less strain on the machine.
- * Knee operated Filling Lever allowing hands to be free for sausage handling
- * Release of Knee Lever automatically stops the piston and stops the filling process
- * Simple & Quick operation
- * Easy & quick to dismantle for thorough cleaning
- * Removable Barrel
- * Electrical parts are enclosed in an IP 65 standard watertight box
- * Reduced labour costs – in filling & cleaning
- * No product over-run when filling casings
- * 0.75 kW motor
- * Supplied with 3 standard nozzles & hydraulic oil
- * Quick and easy to clean – no tool required
- * 3.3 metre heavy duty power lead
- * Rust proof poly feet to protect the floor from rust mark & scratches

TECHNICAL SPECIFICATIONS

	20 kg	27 kg
Height	1190 mm	1315 mm
Diameter	450 mm	450 mm
Nozzle Height	1170 mm	1295 mm
Weight	120 kg (packed)	130 kg (packed)
Capacity	20 kg	27 kg
Motor	0.75 kW (1 H.P.) 4 pole	0.75 kW (1 H.P.) 4 pole
Amps	1.4 A/ph	1.4 A/ph
Power Supply Requirements	415 V , 3 Phase, 50 Hz, 10 amps	

Standard inclusions: 1 x 1/2 inch Nozzle, 1 x 14 mm Nozzle, 1 x 3/4 inch Nozzle, Hydraulic Oil

OPTIONAL EXTRAS (must be specified with order)

- Standard nozzle sizes available to choose from: - 12 mm, 1/2", 3/4", 1 1/4"
- Other custom made nozzle sizes available on request
- Stainless Steel Lockable Castor wheels

Specifications are subject to change without notice.

Manufactured and distributed by:-

Hall Food Equipment

A.B.N. 90 144 988 689

11 Distribution Place, SEVEN HILLS, NSW 2147

PHONE: +61 (0)2 9838 0799 FAX: +61 (0)2 9838 0399

E-mail: info@hallfood.com.au

web: www.hallfood.com.au

Hall
FOOD EQUIPMENT

Contact us for a list of un-biased Hall Equipment users in your region/state.